

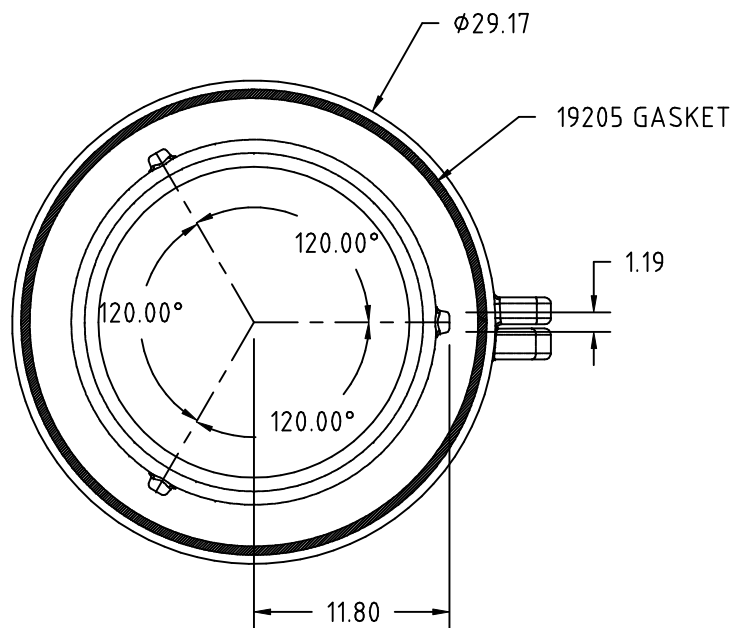
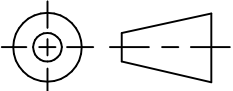

TO INSURE UNIFORM GASKET
INSTALLATION DEPTH USE
ROLLER INSTALLATION TOOL



				DRAWN / DATE REH / 4/5/05	MATERIAL BLACK REGRIND	 Ace Roto-Mold A DIVISION OF DEN HARTOG INDUSTRIES, INC. 4010 HOSPERS DRIVE S., BOX 425, HOSPERS, IOWA 51238	
				APPRD. / DATE REH / 4/5/05			CLIENT / DESCRIPTION 7" SEPTIC TANK EXTENSION ASSEMBLY
REV	DESCRIPTION	DATE	APPRD	THIRD ANGLE PROJECTION ANSI 14.5M 		NOTES: 1. NOM. WALL @ .150 2. BLACK COLOR 3. SHOT WEIGHT 13 LBS.	
ALL DIMENSIONS ARE IN DECIMAL INCHES TOLERANCES UNLESS OTHERWISE SPECIFIED ± 1% @ 68° F						SCALE N.S.	PART NO. 19365